

Features

- Operates at 120 and 277 VAC ± 10%
- Fully dimmable with Reverse (3-wire ELV) Phase Dimmers
- Instant-On™ Technology (Patent Pending)
- UL 1310 Recognized Class 2 Output
- Exceeds Energy Star SSL 1.1 Criteria
- 3-Year Warranty
- Active PFC
- 83% Efficiency
- Designed for IC applications
- Two wire exit location options available
- Constant Current Output



Environmental Specifications

Operating Temperature	-20 to 60 °C
Storage Temperature	-40 to 80 °C
Humidity	5 to 95%
Lifetime	50,000 Hours (5.7 Years) $T_C \leq 80\text{ °C}$ 26,280 Hours (3 Years) $T_C \leq 90\text{ °C}$

Electrical Specifications

Input Voltage	120 VAC ± 10%	277 VAC ± 10%
Input Current	< 125 mA	< 60 mA
Input Frequency	60 Hz	
Power Factor	0.99	0.92
THD	15 %	20 %
EMI	FCC Title 47CFR, Part 15 Class B	FCC Title 47CFR, Part 15 Class A

Output Current ¹	935 mA
Output Voltage	10 –16 V
Ripple Current	< 20%
Maximum Compliance Voltage	16 VDC
Protection	Output Open/Short Protection
Dimming Range ²	5% - 95% Nominal Output Current

¹ +/- 5% from 10 to 16 VDC over operating temperature range

² Tested with 120 VAC ELV Dimmer (Norlux is not aware of 277 VAC ELV dimmers)

Model Numbers

Model Number: NPSCC-02-C0900-2-2 (Bottom wire exit style)
Part Number: 130608

Model Number: NPSCC-02-C0900-1-2 (Side wire exit style)
Part Number: 130694

	NORLUX CORPORATION 575 RANDY ROAD CAROL STREAM, IL 60188-2121	CREATED BY: DH	SAP #: 130608
		CREATED DATE: 8/31/09	PAGE: 1 of 1
TITLE: Norlux 15W CC Driver, 120/277VAC, 900mA, ELV Dimmable		CHECKED BY: JG	DRAWING NO.
		APPROVED BY: DH	N0900-0101
			REV. R02

Mechanical Specifications

Dimensions in inches
 Weight = 6 oz. (170 gm)
 All wires 18 AWG



Wire Exit Code 1
 Side Exit, Opposite Ends

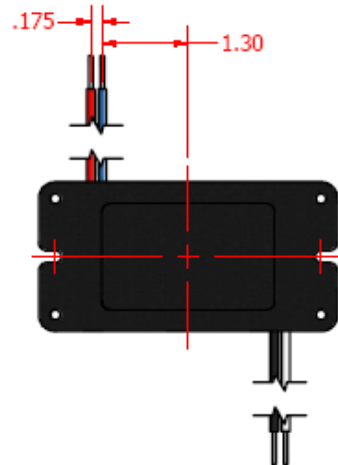
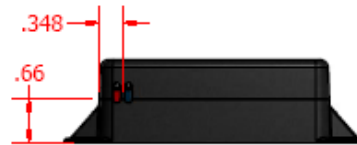
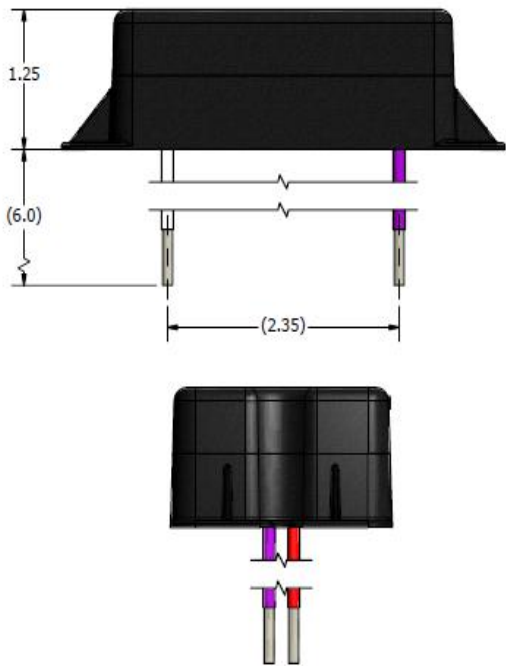
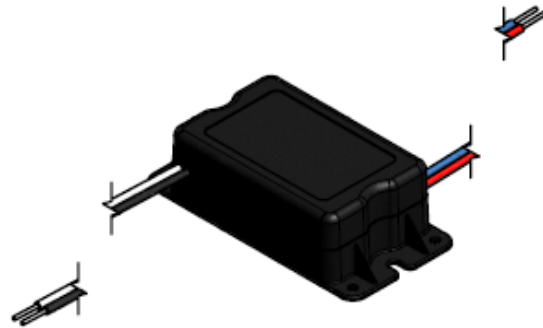

REV	DESCRIPTION	BY	DATE	ECO #
R00	Initial Release	DH	8/31/09	-
R01	Updates	DMH	11/5/09	-
R02	Fixed incorrect model number & updated for side wire exit style	DJB	5/14/10	-

NORLUX

NORLUX CORPORATION
 575 RANDY ROAD
 CAROL STREAM, IL 60188-2121

CREATED BY: DH

SAP #: 130608

CREATED DATE: 8/31/09

PAGE: 2 of 2

TITLE: **Norlux 15W CC Driver, 120/277VAC, 900mA, ELV Dimmable**

CHECKED BY: JG

DRAWING NO.

REV.

APPROVED BY: DH

N0900-0101

R02